

# PS1200 HR/C



## Solar-operated Submersible Pump System, 4" Helical Rotor (HR) or Centrifugal (C) Pump Unit

### Characteristics

- lift up to 240m
- flow rate up to 21m<sup>3</sup>/h
- simple installation
- maintenance-free
- high reliability and life expectancy
- cost-efficient pumping

### Applications

- drinking water supply
- livestock watering
- pond management
- irrigation
- etc.

### Components

#### Controller PS1200

- controlling of the pump system and monitoring of the operating states
- mounted at surface (no electronic parts submerged)
- two control inputs for well probe (dry running protection), float or pressure switches, remote control etc.
- automatic reset 20 minutes after well probe turns pump off
- protected against reverse polarity, overload and high temperature
- speed control, max. pump speed adjustable to reduce flow rate to c. 30%
- solar operation: integrated MPPT (Maximum Power Point Tracking)
- battery operation: low voltage disconnect and restart after battery has recovered
- max. efficiency 92% (motor + controller)
- enclosure: IP 54 (sealed, weatherproof)

#### Motor ECDRIVE 1200HR/C

- brushless DC motor
- no electronics inside motor
- water filled
- IP68, pressure balanced, unlimited submersion
- dynamic slide bearings, material: carbon/ceramic
- wetted material: stainless steel (AISI 316), POM, rubber, cable drinking water approved

#### Pump End (PE)

- high life expectancy
- none-return valve
- dry running protection (optional)
- material: stainless steel (AISI 316), rubber

#### HR Pumps Only

- helical rotor pump (positive displacement pump)
- two main parts only: stator and rotor, field serviceable
- stator: geometry made of abrasion resistant rubber
- rotor: stainless steel, hard chrome plated, abrasion resistant
- more resistant to damage by sand than other pump types
- self-cleaning

### Performance

PS1200	HR-03	HR-03H	HR-04	HR-04H	HR-07
article #	1228-X	1230-X	1235-X	1240-X	1245-X
lift [m]	0-140	140-240	0-80	80-160	40-120
max. flow rate [m <sup>3</sup> /h]	0.5	0.5	0.8	0.8	1.2
max. efficiency [%]	60	64	60	65	64
solar operation	nominal voltage 72-96V DC, open circuit voltage max. 200V DC				
solar generator [Wp]	350-480	420-900	350-420	420-1200	420-1200
battery operation	nominal voltage 72-96 V DC				

PS1200	HR-10	HR-14	C-SJ5-8	C-SJ8-5	C-SJ12-3
article #	1250-X	1255-X	1222	1223	1224
lift [m]	30-80	0-60	0-40	0-24	0-15
max. flow rate [m <sup>3</sup> /h]	1.9	2.7	7.5	11	21
max. efficiency [%]	64	65	48	48	48
solar operation	nominal voltage 72-96V DC, open circuit voltage max. 200V DC				
solar generator [Wp]	420-1200	350-1200	350-1200	350-1200	350-1200
battery operation	nominal voltage 72-96 V DC				



### System Sizing Table

#### Instructions

1. lift: Find the lift you require and read the column below it.
2. daily volume: Find the daily volume you require at an irradiation of 4.5, 6 or 7.5kWh/m<sup>2</sup>/day. 7.5 is a moderately dry summer
3. pipe sizing: Use peak flow rate for pipe sizing.
4. wire size, max. wire length

solar generator	vertical lift		5 m 16 ft		10 m 33 ft		15 m 50 ft		20 m 65 ft		30 m 100 ft		40 m 133 ft		50 m 165 ft		60 m 200 ft		70 m 230 ft		
	array mounting		fixed	tracked	fixed	tracked	fixed	tracked	fixed	tracked	fixed	tracked	fixed	tracked	fixed	tracked	fixed	tracked	fixed	tracked	
<b>flow rate [m<sup>3</sup>/day]</b>																					
350 Wp	irradiation	7.5	52	78	22	30	23	29	18	26	14	20	6.8	8.7	6.1	8.3	5.7	7.9	4.9	6.8	
		6.0	43	62	19	26	18	24	15	20	10	14	6.5	8.3	5.5	7.5	4.8	6.9	4.1	5.8	
	4.5	33	44	16	22	14	19	10	14	6	8	6.0	8.0	4.7	6.2	4.0	5.6	3.5	4.8		
	peak flow rate [l/min]		125		47		40		36		30		13		13		11		9.8		
	wire size/max. length		4mm <sup>2</sup> / 60m #12 / 200ft										4mm <sup>2</sup> / 70m #12 / 230ft								
420 Wp	irradiation	7.5	60	90	26	31	24	30	20	29	16	23	8.7	13	6.8	8.7	6.1	8.3	5.7	7.6	
		6.0	50	72	22	27	19	25	17	24	12	17	7.5	11	6.0	7.9	5.4	7.2	4.8	6.4	
	4.5	39	53	17	24	15	21	14	19	8	11	6.5	8.7	5.0	7.0	4.5	6.0	4.0	5.4		
	peak flow rate [l/min]		135		43		42		38		34		20		13		11		10		
	wire size/max. length		4mm <sup>2</sup> / 60m #12 / 150ft										4mm <sup>2</sup> / 80m #12 / 230ft								
480 Wp	irradiation	7.5	66	95	34	49	30	43	22	30	18	26	14	20	11	14	8.7	13	6.1	8.7	
		6.0	56	80	28	38	24	32	19	27	15	19	10	14	8.5	12	7.0	10	5.5	7.4	
	4.5	44	60	22	28	18	24	15	21	12	16	7.0	9.5	5.5	7.5	5.0	6.5	4.5	6.0		
	peak flow rate [l/min]		145		80		75		42		36		28		20		19		17		
	wire size/max. length		4mm <sup>2</sup> / 60m #12 / 150ft										4mm <sup>2</sup> / 80m #12 / 200ft								
660 Wp	irradiation	7.5	82	112	60	86	38	57	26	30	22	29	17	25	14	19	9.8	14	8.7	13	
		6.0	71	98	50	70	32	46	23	29	18	24	14	19	11	15	8.5	12	7.3	11	
	4.5	56	74	36	47	24	33	19	25	14	19	10	14	8.0	10	7.0	9.5	6.0	8.5		
	peak flow rate [l/min]		165		135		90		43		42		40		38		20		20		
	wire size/max. length		4mm <sup>2</sup> / 60m #12 / 150ft										4mm <sup>2</sup> / 80m #10 / 300ft								
720 Wp	irradiation	7.5	87	125	66	93	42	61	33	47	24	30	20	29	18	26	11	14	10	14	
		6.0	76	106	54	78	35	50	26	36	20	26	18	25	14	19	10	14	9	13	
	4.5	59	80	39	53	25	34	22	30	17	24	16	21	9	12	9	12	8	11		
	peak flow rate [l/min]		175		145		95		75		44		43		39		20		20		
	wire size/max. length		4mm <sup>2</sup> / 60m #10 / 250ft										4mm <sup>2</sup> / 80m #10 / 300ft								
840 Wp	irradiation	7.5	96	133	74	110	57	85	40	60	24	30	22	30	19	27	14	20	10	14	
		6.0	84	110	63	91	45	65	33	47	22	29	21	28	16	23	12	17	10	14	
	4.5	68	92	46	62	30	41	25	34	20	26	18	24	13	18	10	14	9	13		
	peak flow rate [l/min]		185		170		150		95		45		43		39		30		20		
	wire size/max. length		4mm <sup>2</sup> / 60m #10 / 250ft										4mm <sup>2</sup> / 70m #10 / 300ft								
1000 Wp	irradiation	7.5	145	205	84	125	66	100	43	60	34	48	23	30	21	29	17	25	14	20	
		6.0	130	185	73	105	55	78	34	45	27	36	22	28	18	25	14	21	12	17	
	4.5	103	140	47	65	39	51	26	33	23	31	20	25	15	20	12	16	10	14		
	peak flow rate [l/min]		310		180		160		100		90		52		39		38		30		
	wire size/max. length		4mm <sup>2</sup> / 40m #10 / 170ft										4mm <sup>2</sup> / 70m #10 / 300ft								
1200 Wp	irradiation	7.5	160	225	120	180	78	110	60	88	42	60	32	45	22	30	18	26	15	21	
		6.0	150	190	96	134	65	90	47	64	34	44	25	33	20	27	16	23	14	19	
	4.5	125	165	67	90	46	63	33	45	25	34	18	23	18	24	14	19	12	16		
	peak flow rate [l/min]		340		285		165		145		90		67		39		38		30		
	wire size/max. length		4mm <sup>2</sup> / 40m #10 / 170ft										4mm <sup>2</sup> / 70m #10 / 300ft								

\*) For 1000Wp/30m (C-SJ5-8) and 1200Wp/40m (C-SJ5-8): use 7-8 panels, wired in series, e.g. required system voltage 84/96V

#### System Voltage

72-96V nominal, e.g. 6-8 standard 12V modules wired in series, Voc 200V max.

#### Lift Limits

These systems are selected for optimum performance. To allow unexpected drawdown, each system can handle an additional 15% lift.

#### Wire Sizes

Cable layout is calculated to stay within 4% power loss.

Pump cable: example: 4mm<sup>2</sup>/60m = maximum allowable length (controller to pump) for the given wire size.

#### Variations of Wire Length

Longer: for each 50% increase, the next larger wire size is required.

Shorter: for each 33% decrease, the next smaller wire size is possible.

Array to controller: up to 6m/20ft: min. 4mm<sup>2</sup>/#10

Controller to low-water-probe: min. 1mm<sup>2</sup>/#18, 2-conductor

**Conversion for Flow Rates**

1 m <sup>2</sup>	264 US Gal.
1 m <sup>2</sup>	220 Imp. Gal.
1 l/min	0.264 US Gal./min
1 l/min	0.220 Imp. Gal./min

**Conversion for Lift/Length**

1 m	3.3 ft
-----	--------



80 m 265 ft	90 m 300 ft	100 m 330 ft	120 m 400 ft	140 m 460 ft	160 m 530 ft	180 m 600 ft	200 m 660 ft	230 m 760 ft	vertical lift	solar generator
fixed	tracked	fixed	tracked	fixed	tracked	fixed	tracked	fixed	tracked	

**flow rate [m<sup>3</sup>/day]**

3.8	5.1	3.4	5.0	3.2	4.7	3.0	4.3	2.7	4.0	7.5 6.0 4.5	irradiation kWh/ m <sup>2</sup> /day	350 Wp								
3.3	4.4	3.0	4.0	2.7	3.9	2.5	3.3	2.0	2.9											
2.8	3.8	2.6	3.5	2.2	3.0	1.7	2.3	1.3	1.8											
HR-03																				
8.3		7.6		7.2		6.8		6.4												
4mm <sup>2</sup> / 140m #10 / 500ft																				
4.7	6.9	4.5	5.4	4.0	5.0	3.7	5.0	3.0	4.2	2.3	3.2	1.7	2.4	7.5 6.0 4.5	irradiation kWh/ m <sup>2</sup> /day	420 Wp				
3.9	5.5	3.7	4.7	3.2	4.2	3.0	4.1	2.5	3.4	2.0	2.7	1.4	1.9							
3.0	4.0	2.9	3.9	2.4	3.3	2.3	3.2	2.0	2.7	1.7	2.2	1.0	1.4							
HR-04H		HR-03				HR-03H														
9.5		7.9		7.6		7.2		6.8		6.1		5.3								
#10 / 400ft		4mm <sup>2</sup> / 140m #10 / 500ft				6mm <sup>2</sup> / 180m #8 / 750ft														
5.7	8.2	5.5	8.0	5.0	7.0	4.5	6.5	3.3	4.5	2.8	4.0	2.3	3.0	1.9	2.7	1.6	2.3	7.5 6.0 4.5	irradiation kWh/ m <sup>2</sup> /day	480 Wp
4.8	6.7	4.4	6.5	3.8	5.3	3.4	4.8	3.0	4.0	2.4	3.3	1.9	2.5	1.6	2.2	1.3	1.8			
3.9	5.2	3.3	4.5	2.6	3.5	2.2	3.0	2.6	3.5	1.9	2.5	1.5	2.0	1.2	1.6	1.0	1.3			
HR-04H				HR-03				HR-03H												
12		11		10		9.5		7.2		6.4		6.1		6.1		6.1				
4mm <sup>2</sup> / 110m #10 / 450ft				#10 / 500ft				6mm <sup>2</sup> / 180m #8 / 750ft		8mm <sup>2</sup> / 230m #8 / 750ft										
8.0	11.5	6.5	8.0	5.5	7.8	5.1	7.4	4.5	6.4	3.3	4.6	3.2	4.3	3.0	4.1	2.1	3.7	7.5 6.0 4.5	irradiation kWh/ m <sup>2</sup> /day	660 Wp
6.5	9.2	5.5	7.4	4.9	6.7	4.0	5.8	3.5	5.0	3.0	4.2	2.8	3.7	2.5	3.3	1.8	2.8			
5.0	7.0	4.5	6.0	4.3	5.5	3.0	4.2	2.5	3.5	2.7	3.7	2.4	3.2	2.0	2.5	1.5	2.0			
HR-07		HR-04H				HR-03H														
19		13		13		12		12		6.8		6.8		6.8		6.8				
#10 / 300ft		6mm <sup>2</sup> / 170m #10 / 450ft				6mm <sup>2</sup> / 180m #8 / 750ft		8mm <sup>2</sup> / 230m #8 / 750ft												
9.4	14	8.7	13	6.0	8.0	5.7	8.0	5.3	7.0	3.7	5.0	3.5	4.7	3.3	4.2	3.0	4.0	7.5 6.0 4.5	irradiation kWh/ m <sup>2</sup> /day	720 Wp
8.2	12	7.4	11	5.8	7.0	5.0	6.5	4.4	5.9	3.5	4.7	3.3	4.4	3.0	3.9	2.5	3.4			
7.0	9.5	6.0	8.1	5.5	6.1	4.0	5.4	3.5	4.7	3.3	4.5	3.0	4.0	2.7	3.6	2.0	2.7			
HR-07		HR-04H				HR-03H														
20		19		13		13		12		6.8		6.8		6.8		6.8				
4mm <sup>2</sup> / 100m #10 / 350ft		6mm <sup>2</sup> / 170m #10 / 500ft				6mm <sup>2</sup> / 180m #8 / 750ft		8mm <sup>2</sup> / 230m #8 / 750ft												
10	14	9.4	14	8.0	12	7.2	11	6.0	7.2	4.2	5.2	4.0	5.0	3.7	4.4	3.3	4.2	7.5 6.0 4.5	irradiation kWh/ m <sup>2</sup> /day	840 Wp
8.9	12	8.4	12	7.3	10	6.5	9.0	5.2	6.4	3.9	5.0	3.6	4.7	3.4	4.2	3.1	4.0			
7.8	10	7.3	9.8	6.5	8.8	5.5	7.4	4.4	6.0	3.5	4.7	3.2	4.3	3.0	4.1	2.8	3.8			
HR-07		HR-04H				HR-03H														
20		19		18		17		12		6.8		6.8		6.8		6.8				
4mm <sup>2</sup> / 100m #10 / 400ft		6mm <sup>2</sup> / 130m #10 / 400ft		#10 / 500ft		6mm <sup>2</sup> / 180m #8 / 750ft		8mm <sup>2</sup> / 230m #8 / 750ft												
13	18	10	14	9.0	13	8.5	12	6.5	8.0	7.5 6.0 4.5	irradiation kWh/ m <sup>2</sup> /day	1000 Wp								
11	15	9.0	12	8.0	11	7.6	11	5.8	7.4											
9.0	12	8.0	11	7.0	9.5	6.7	9.0	5.0	6.8											
HR-10		HR-07				HR-04H														
30		19		18		17		12												
#10 / 300ft		6mm <sup>2</sup> / 130m #10 max. 400ft				#10 / 500ft														
14	20	11	14	10	13	9.5	12	7.0	8.3	7.5 6.0 4.5	irradiation kWh/ m <sup>2</sup> /day	1200 Wp								
13	17	10	13	9.0	12	8.5	11	6.4	8.3											
11	15	9.2	12	8.0	11	7.5	10	5.7	7.7											
HR-10		HR-07				HR-04H														
29		19		18		17		12												
#10 / 300ft		6mm <sup>2</sup> / 130m #10 max. 400ft				#10 / 500ft														

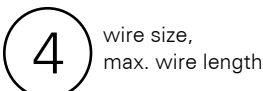
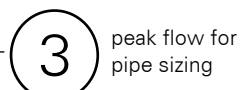

**Calculation of Daily Water Volume**

Daily volume is calculated by integrating real flow versus realistic solar (PV) output throughout the day.

Calculations include a 10% PV output degradation (heat, dirt etc.). Cable losses are included at maximum allowable length. The solar array is fixed at tilt angle = latitude of the location.

Irradiation: kWh/m<sup>2</sup>/day = peak sun hours/day

Flow rates may vary by +/- 10%

**Conversion for Wire Sizes**

AWG	mm <sup>2</sup>
# 18	1
# 12	4
# 10	6
# 8	10
# 6	16

Table shows nearest larger metric cross section.

## Technical Data, Dimensions and Weights

	dimensions					shipping dimensions			
	L [mm]	A [mm]	B [mm]	D [mm]	S [mm]	packaging [mm]	shipping volume [m <sup>3</sup> ]	net weight [kg]	gross weight [kg]
Pump Unit (PU) (motor + pump end)									
HR-03, HR-03H, HR-04, HR-04 H	780	595	185	96	G 1 1/4"	850×160×150	0.0204	11.2	12.0
HR-07, HR-10, HR-14, HR-20	771	586	185	96	G 1 1/4"	850×160×150	0.0204	11.5	12.3
C-SJ5-8	524	339	185	96	G 1 1/2"	660×160×150	0.0158	11.2	12.0
C-SJ8-5	600	415	185	96	G 2"	660×160×150	0.0158	12.7	13.5
C-SJ12-3	565	380	185	96	G 2"	660×160×150	0.0158	12.5	13.3
Controller									
PS1200						450×250×240	0.0270	4.5	5.3

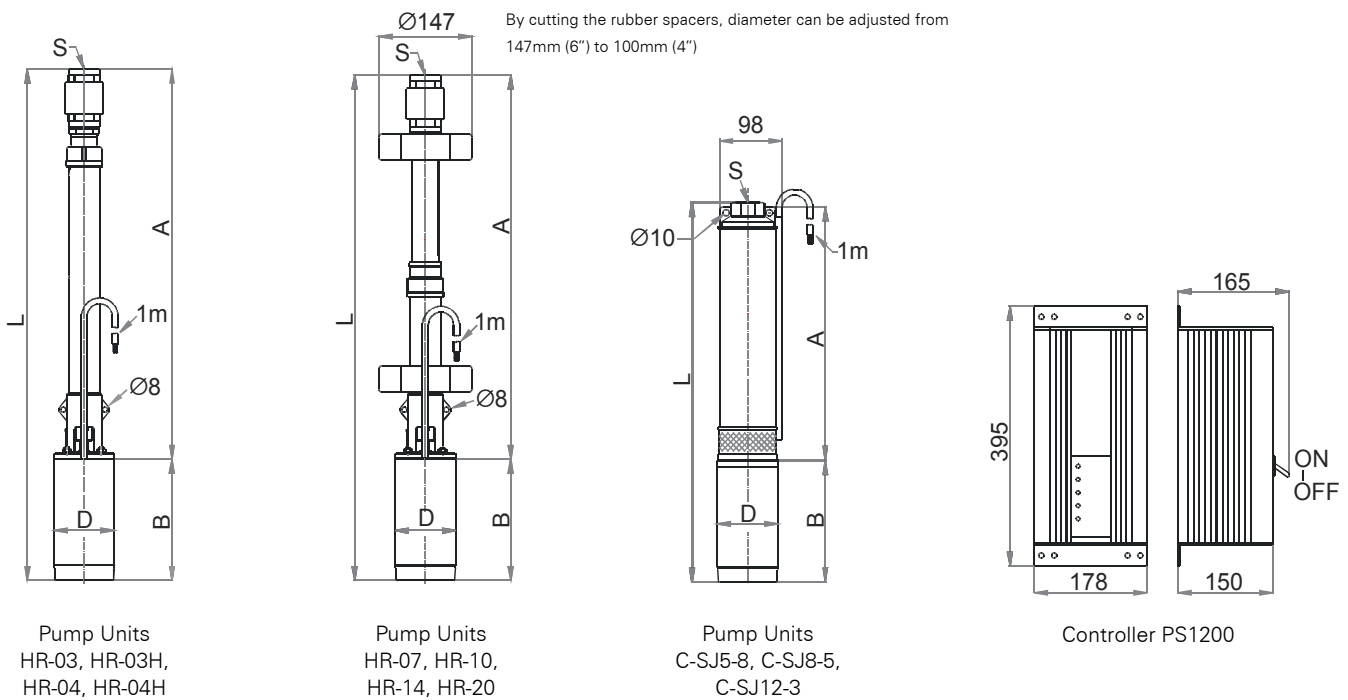

### Sand and Silt Tolerance

The pump (HR) has a higher resistance to wear from sand, clay etc. than any other pump type. In properly constructed wells the amount of particles is within the tolerance of the pump.

A concentration of particles higher than 2% (by volume) may cause blockage in the pump or the drop pipe, especially at low flow rates.

Do not use the pump to clean out a dirty well.

### Pump Cable and Splice

Standard submersible cable, 3-wire + ground (total four wires). Connection to the pump is made using industry-standard splicing methods.

### Drop Pipe

G 1 1/4" (optional: 1" NPT) pump outlet. If water is dirty consider a smaller sized drop pipe to increase the flow velocity. This helps to exhaust solid particles and prevent accumulation in the pipe. When considering reduced pipe size, consult a pipe sizing (friction loss) chart. Pipe can be of any standard material, rigid or flexible. A torque arrestor is *not* required.

### Temperature Limits

Pump end, motor: water temperature up to +40°C (+104°F)

Specify temperature range on order.

Controller: ambient temperature -30°C to +55°C (-22°F to +131°F)

### Warranty

Two years manufacturer's warranty against defects in material and workmanship